

# 58535A and 58536A Option 001 Adapter Plate

## Installation Note

This installation note describes adapter plates for Symmetricom GPS distribution amplifiers for a telecommunications network.

This installation note is the primary document for Option 001 to the 58535A and 58536A Global Positioning System (GPS) Distribution Amplifier.

This document applies to either the 58535A or the 58536A system you have received unless update information is included with the equipment.

For assistance, contact:

Symmetricom, Inc.  
2300 Orchard Parkway  
San Jose, CA 95131-1017

U.S.A. Call Center:  
888-367-7966 (from inside U.S.A. only – toll free)  
408-428-7907

U.K. Call Center:  
+44.7000.111666 (Technical Assistance)  
+44.7000.111888 (Sales)

Fax: 408-428-7998

E-mail: [ctac@symmetricom.com](mailto:ctac@symmetricom.com)

Internet: <http://www.symmetricom.com>

#### Warning Symbols That May Be Used In This Note



Instruction manual symbol; the product will be marked with this symbol when it is necessary for the user to refer to the instruction manual.



Indicates hazardous voltages.



Indicates earth (ground) terminal.



or



Indicates terminal is connected to chassis when such connection is not apparent.



Indicates Alternating current.



Indicates Direct current.

# 58535A Option 001 Adapter Plate

Option 001 to the 58535A GPS Distribution Amplifier provides an adapter plate and associated hardware to support the use of this distribution amplifier with the existing mounting bracket for the 58512A or the 58515A. The 58535A distribution amplifier replaces the 58515A.

## Parts included with Option 001:

- (1) adapter plate
- (4) M3 x 10 mm Phillips machine screw (p/n 0515-1125)
- (4) M3 nut-hex w/lock washer (p/n 0535-0031)
- (2) M4 nut-hex w/lock washer (p/n 0535-0082)

## Tools needed:

small Phillips screwdriver  
5.5 mm and 7 mm open end wrenches.

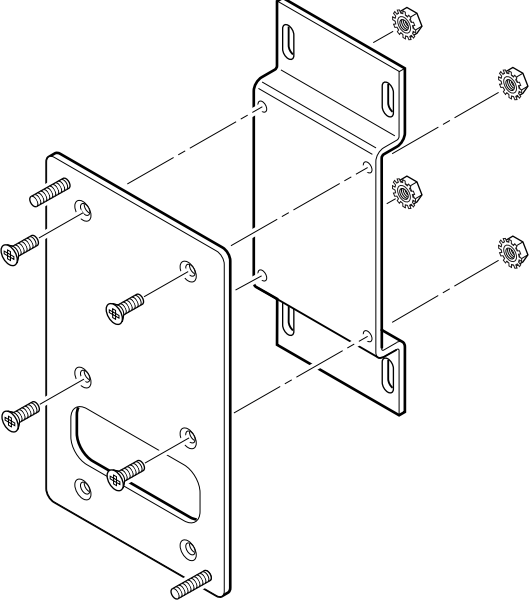
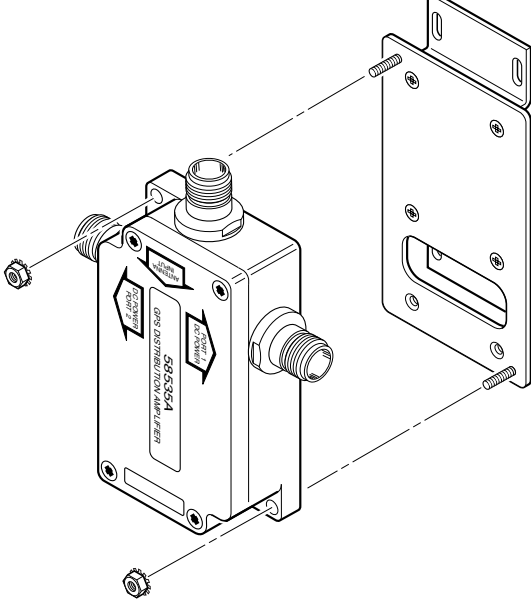
<p><b>Step 1.</b> Remove the old distribution amplifier and mounting bracket from its mounting surface. Remove the amplifier from the bracket.</p>	<p><b>Step 3.</b> Reattach the mounting bracket to the mounting surface.</p>
<p><b>Step 2.</b> Attach the adapter plate to the mounting bracket using the four screws and the nuts. Tighten in place.</p> 	<p><b>Step 4.</b> Place the 58535A over the threaded studs on the adapter plate and tighten in place using the supplied nuts.</p> 

# 58536A Option 001 Adapter Plate

Option 001 to the 58536A GPS Distribution Amplifier provides an adapter plate and associated hardware to support the use of this distribution amplifier with the existing mounting bracket for the 58516A. The 58536A distribution amplifier replaces the 58516A.

## Parts included with Option 001:

- (1) adapter plate
- (4) M3 x 10 mm Phillips machine screw (p/n 0515-1125)
- (4) M3 nut-hex w/lock washer (p/n 0535-0031)
- (2) M4 nut-hex w/lock washer (p/n 0535-0082)

## Tools needed:

small Phillips screwdriver  
5 mm and 7 mm open end wrenches.

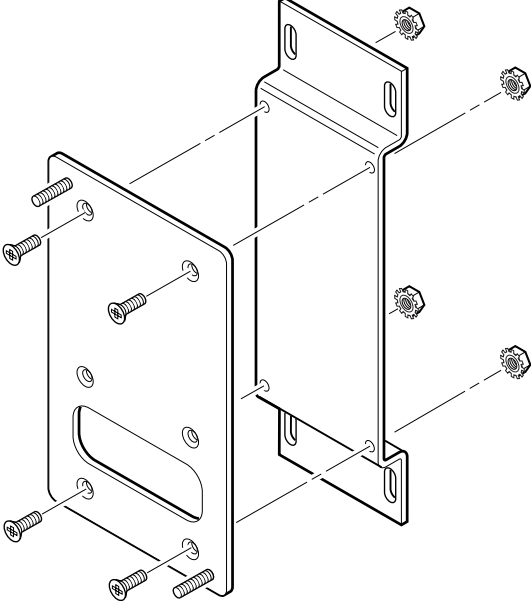
<p><b>Step 1.</b> Remove the old distribution amplifier and mounting bracket from its mounting surface. Remove the amplifier from the bracket.</p>	<p><b>Step 3.</b> Reattach the mounting bracket to the mounting surface.</p>
<p><b>Step 2.</b> Attach the adapter plate to the mounting bracket using the four screws and the nuts. Tighten in place.</p> 	<p><b>Step 4.</b> Place the 58536A over the threaded studs on the adapter plate and tighten in place using the supplied nuts.</p> 